



ADF Series

AC Power Sources

Single or Three Phase AC Power Sources

All Digital Power Conversion Technology

Extensive Features:

- Single Phase or Three Phase Models
- AC Output Capability
- DC Output Mode Option
- Constant Power Mode Voltage Range to 300Vac LN/520Vac LL. (Optional 333Vac L-N/576Vac LL with V Option)
- Optional Output Transformers for Higher Voltage Ranges
- No need to switch between high and low voltage ranges
- Frequency range 45-500Hz (Optional 15-1200Hz with F Option)
- Active Three Phase PFC input with Inrush Current Limiting
- Precise Output Voltage and Load Regulation
- Metering of Volts, RMS Current, Peak Current, Apparent Power & True Power on all Phases
- Unique Sleep Modes Save Energy, Reduces needless Heat Generation and Extends the Life of the Power Source
- Standard USB, LAN & RS232, GPIB Interfaces
- Compact size, 15kVA in 4U Rack space
- Light weight, only 51Kg per chassis
- Modular Parallel Master/Slave Systems for higher power requirements
- Energy Saving Stand-by Mode

15kVA to 90kVA

AC: 0-300 VAC LN / 0-520 VAC LL
Option: 0-400 VAC LN / 0-690 VAC LL
Frequency: 45 - 500 Hz
Option: 15 - 1000 Hz



Single Phase



Three Phase



"Cost Effective Solutions for Production Power Testing"



Patented Technology

THE POWER OF EXPERTISE



FREQUENCY CONVERSION



AEROSPACE



R & D



MILITARY



MANUFACTURING



CUSTOM

Total Control, Metering and Analysis of AC Power. Simple

Control

PROGRAM

Settings
3ph

Measurements
A B C

↔

Apply All

Freq.	50.01	50.01			Hz	Protection
Volt. AC	230.0	230.0	230.0	230.0	V _{RMS}	
Curr. lim.	41.7	34.7	34.3	34.8	A _{RMS}	
Pow. lim.	5.00	7.58	7.61	7.84	kW	
kVA lim.	5.00	7.98	7.89	8.00	kVA	

Enabled

Prog. MAN

V/M

REM

3ph

More

Metering

MEASUREMENTS 1 OF 2

Freq. 400.00 Hz

Phase A

Phase B

Phase C

Volt. L-N	115.00	115.00	115.00	V _{RMS}
Current	25.67	25.67	25.67	A _{RMS}
Power	2.655	2.555	2.655	kW
	V _{AB}	V _{BC}	V _{CA}	
Volt. L-L	199.20	199.19	199.20	V _{RMS}

Meas. Page 2

Fault Status

Error and Event

Real Time Plot

Individual Phase

Ready

Prog. MAN

LOC

3ph

More

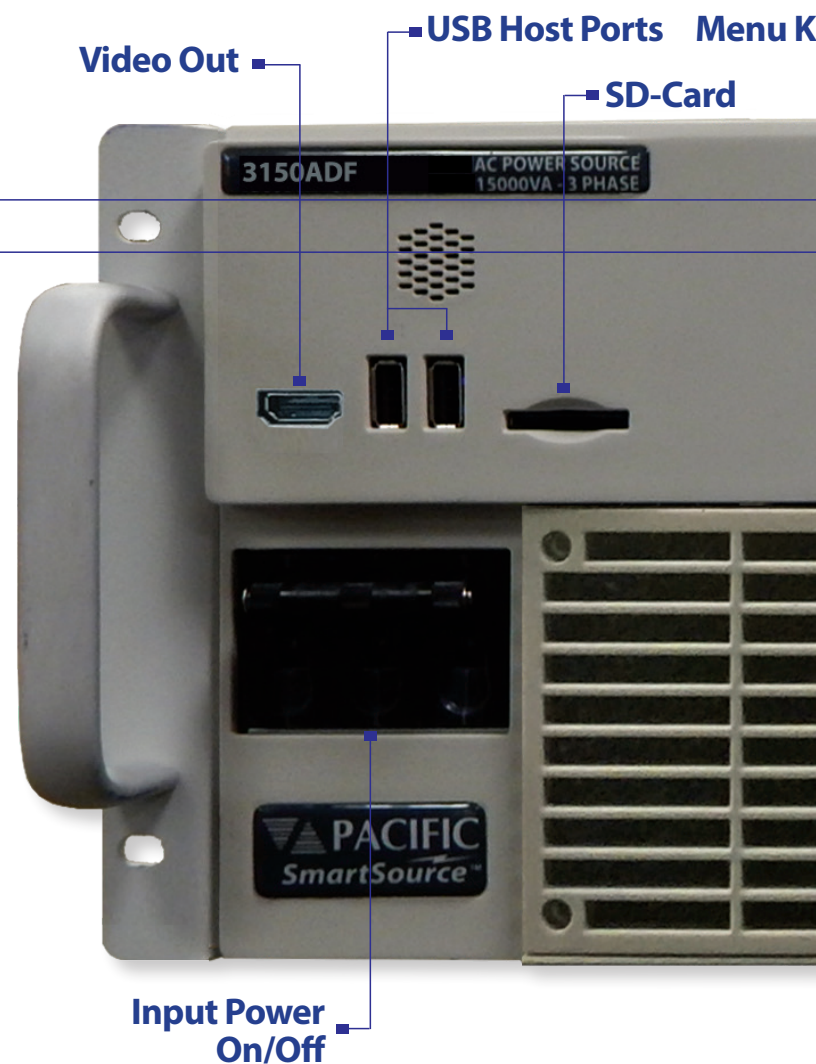

Industrial and Consumer Product Test

Growing demand for power to support increasingly complex consumer products and appliances as well as UPS, Electric Vehicle (EV) Chargers and AC/DC power supplies means more power is needed in often limited amounts of space. The ADF Series addresses this need by offering power density three times higher than its nearest competitor.

With extensive control over voltage, current and frequency, the ADF series is capable of handling demanding production test requirements with minimal programming effort.



Simple, Intuitive Operation

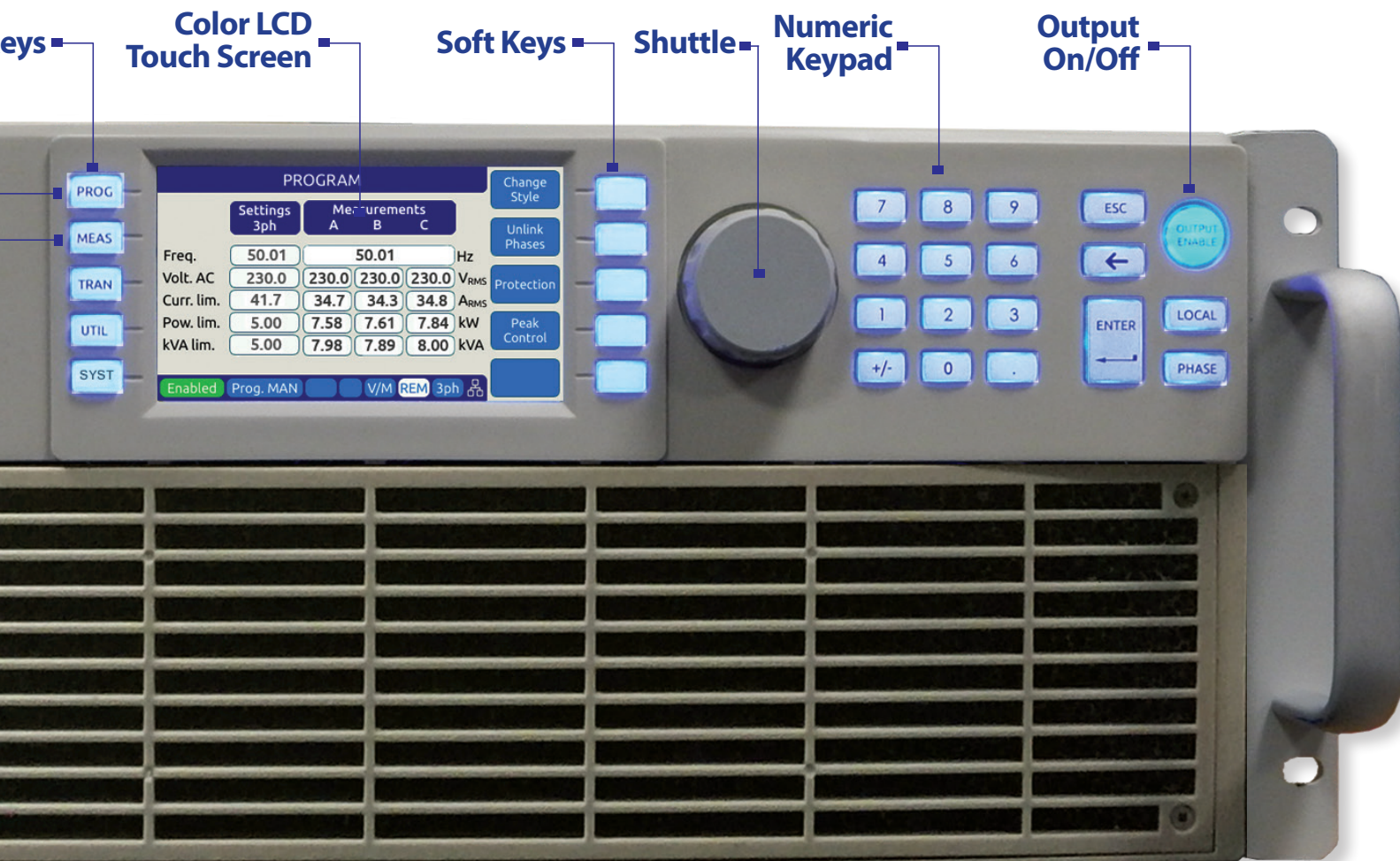

Avionics Power Test

The advanced digital power conversion technology used in the ADF Series Power Source results in higher power density than any other offering. A standard frequency range of 45Hz to 500Hz supports 400Hz fixed frequency avionics applications. For more demanding avionics testing, the F option extends output frequency to 1200Hz to support 360Hz to 800Hz wild frequency development and test as well.

High power, three-phase power configurations are available to match ever increasing power test demands of larger aircraft. As needs change over time, additional auxiliary units can be added easily to keep up with your test needs while protecting your original investment.



Powerful yet Easy to Use

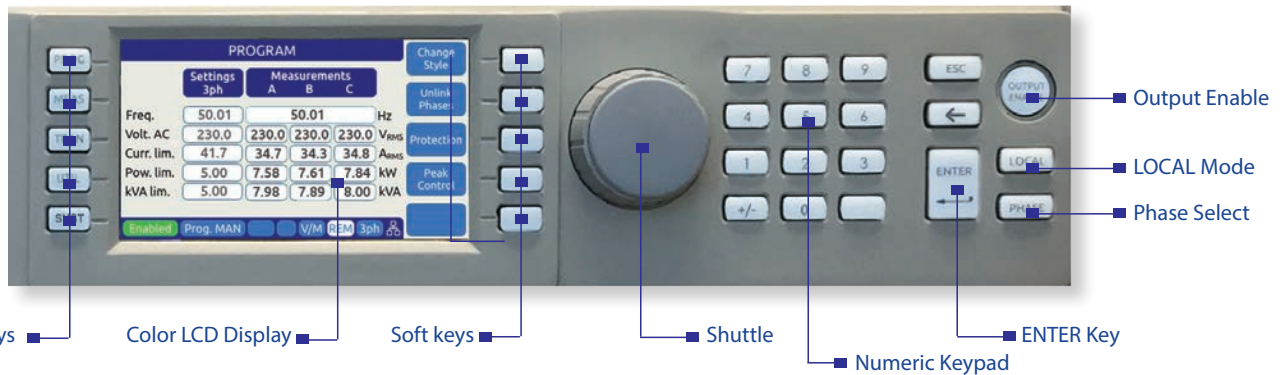

Although ADF Series power sources offer a wide range of operating modes and features, they are easy to operate through a large full color LCD display and soft key driven menus. Top level menus are always available directly by pressing any of the five menu keys on the left of the

display. Entering setup data is accomplished using the numeric keypad or the shuttle. Operating status is shown on screen using various colors to distinguish between setting, measurements and operator warnings, or error messages.

Constant Power Voltage Range

Traditional AC power sources use two voltage ranges to provide either high voltage or high current. By contrast, the ADF Series uses a unique single voltage range that operates along a constant power curve. This provides more current at low voltages, eliminating the need to switch between voltage ranges and provides a much wider operating range (demonstrated as green in the figure to the right).

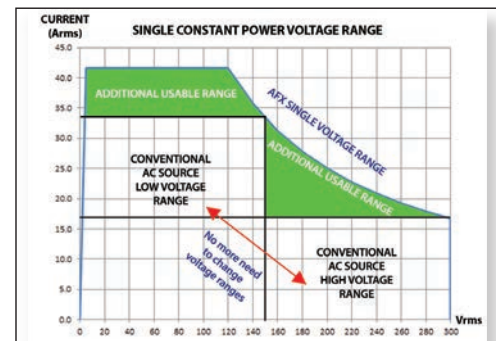

Available Options Extended Application Coverage

Voltage & Frequency ranges of the ADF Series can be extended using the available "V" and/or "F" options. On three phase ADF models, a single phase output option "M" is available as an option as well. Also available is a DC output mode option "D".

Option V:

The extended voltage range capability allows the standard ADF power source to address additional high voltage test requirements. This extended range increases the maximum output voltage to 333Vac L-N / 576Vac L-L. This supports over voltage testing up to 20% for 480V nominal powered equipment. It also allows testing of single phase universal 90V ~ 265V AC input products to 120% of their maximum nominal input specification.

Option F:

The extended frequency range option supports testing electrical railway equipment (16.6Hz) or testing wild frequency avionics equipment (360Hz-800Hz) by extending the standard ADF Series frequency range to 15Hz-1200Hz.

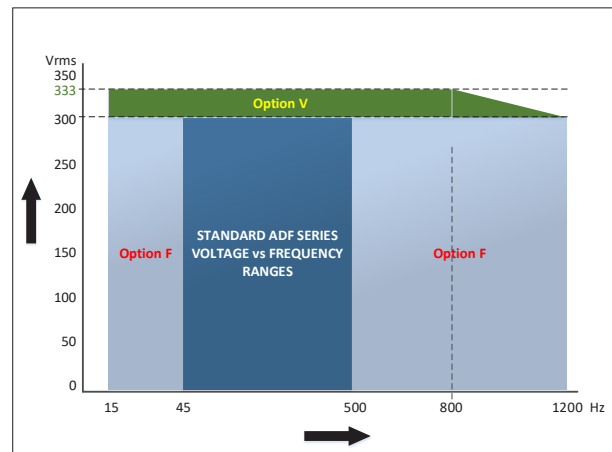

Option D:

The D option adds DC output mode to the AC Source. In DC mode, bipolar $\pm 425\text{Vdc}$ voltage output is available .

Option M:

Single phase output option. This option allows a three phase ADF model to be configured in single phase output mode so all current and power is available on phase A only.

High Voltage Output Transformers (T Option)

If the 333Vac_{LN} / 576Vac_{LL} V Option is still not sufficient, the ADF power source can be equipped with an optional output Transformer module. For power levels up to 15kVA/kW, a single ADF style 4U chassis is added. This chassis contains three step-up transformers, one for each phase. This adds a voltage range capable of supporting the following output voltages:

Single Phase ADF Models **Three Phase ADF Models**
 0-400 V_{LN} 0-400 V_{LN}/0-692 V_{LL}

Standard voltage ranges remain available. Transformer options for 500V_{LN} and 600V_{LN} applications are available as well. Contact factory or PPS representative for details

Full Frequency Range

The transformer does not reduce the available output power on standard ADF models. Maximum voltage is reduced linearly from 45Hz down to 15Hz¹ and max. current from 1000Hz to 1200Hz on ADF units with the -F Option.

Selecting the AC high voltage range is controlled from the front panel or using SCPI commands over one of the remote control interface.

Constant Power Mode

The 400V transformer range has a constant power profile. That means full power is available all the way down to 160 Vac_{LN}/277 Vac_{LL} on the 400V range.



3150ADFT Shown with **Optional 4U T-Option Chassis**

Voltage Sense

The voltage sense on the 400Vac range is connected to the secondary side of the output transformer and re-scales automatically for the higher voltage range limit. This ensures optimal voltage accuracy at the load despite the higher voltage range and compensates for any transformer impedance induced load regulation errors.

T Option - Technical Specifications 400V

ELECTRICAL	Specification
Voltage Range	
3 Phase ADF Models	0-400 Vac _{LN} / 0-692Vac _{LL}
1 Phase ADF Models	0-400 Vac _{LN}
Resolution	0.01 V
Accuracy	± (0.25% + 0.25* f (kHz)) F.S.
Voltage Sense	Auto scales for T option range
Frequency Range	45Hz - 1000Hz Deratings: Current > 1000Hz of ADF models with -F Option
Constant Power Mode	From 40% to 100% of V range

MECHANICAL	Specification
Mechanical - T Option Chassis (15kVA rated)	
H x W x D	7.0" x 17.0" x 25.0" 178 x 482 x 635 mm
Weight	170 lbs. / 77.1 kg
Mechanical - Cabinet Systems	
Dimensions / Weight	Cabinet Systems from 30kVA to 60kVA are available with T Options. See table page 7

Transformer Option Ordering Information

- Standard "T" option is 400Vac_{L_N}. Consult factory for other voltage ranges
- 4U Transformer Chassis is not included on 1150ADFT or 3150ADFT single chassis models and must be added as a line item.

Cabinet Systems

The wide range of available power levels combined with the small form factor of the ADF Series allows these power systems to be deployed in small spaces if needed. This feature reduces required floor space and eliminates most load bearing floor issues that can be associated with raised floors. Systems above a 15 kVA power level can be shipped pre-installed and pre-wired in standard

19" heavy duty steel cabinets with casters and levelers for ease of mobility. Cabinet options such as Outlet sockets and Emergency Power Off (EPO) buttons can be ordered as options. These parallel configurations are also available in **kit form** for system integrators that are planning on using their own cabinets.



ADF User Benefits

The ADF Series is based on a truly revolutionary technology platform that enables functionality not previously found on programmable AC power sources. This results in the following user benefits:

- Small size, 15kVA/kW in 4U rack space.
- Light Weight. Easy to install, inexpensive to ship.
- Modular high power systems. Even if one power module fails, system continues to operate at reduced power.
- Multiple protections for the unit under test. Limit settings for Voltage, RMS Current, Peak Current, Power and apparent Power.
- Dual stage energy savings mode. Saves on energy cost, extends equipment lifespan.



Available Standard Model Configurations

ADF Series AC Sources are available with either single phase output up to 45kVA or with three phase output up to 90kVA. Models listed in the table below are rack mount or bench units. Cabinet systems are pre-wired for

both input and output power. For other configurations or power levels and cabinet options, contact factory. All models shown here require three phase AC input power.

MODEL	Phase Mode ¹	Rated Power ² AC mode	Voltage Ranges Vac L-N	Max. AC Current ⁴ 3 Phase Mode	Max. AC Current ⁴ 1 Phase Mode	AC Input ³ -2 or -4	Form Factor
1150ADF	1 Phase	15 kVA	0-150V / 0-300 V	n/a	125 Arms (62.5Adc)	-2 or -4	4U Chassis, Bench or Rackmount
3150ADF	3 Phase	15 kVA		41.7 Arms (21.0 Adc)	n/a		
1300ADF	1 Phase	30 kVA		n/a	250 Arms (125.0 Adc)	-2 or -4	Fully wired 18U Cabinet power system or -KIT w/o 19" rack
3300ADF	3 Phase	30 kVA		83.3 Arms (41.7 Adc)	n/a		
1450ADF	1 Phase	45 kVA		n/a	375 Arms (187.5 Adc)		
3450ADF	3 Phase	45 kVA		125.0 Arms (62.5 Adc)	n/a	-4 Only	Fully wired 28U Cabinet power system or -KIT w/o 19" rack
3600ADF	3 Phase	60 kVA		166.7 Arms (83.3 Adc)	n/a		
3750ADF	3 Phase	75 kVA		208.3 Arms (104.0 Adc)	n/a		
3900ADF	3 Phase	90 kVA		250.0 Arms (125.0 Adc)	n/a		
Higher	For configurations up to 150kVA/kW, contact factory						

Note 1: Single Phase Mode option (M) is available on three phase ADF Models. This option adds single phase output mode.

Note 2: Rated power shown is for Three Phase or Single Phase mode operation. For Split Phase mode, rated power is 2/3.

Note 3: AC input ratings: -2 = 208Vac Nominal, 3ø or -4 = 380~480Vac Nominal, 3ø. See specifications section for AC current requirements.

Note 4: DC output current ratings shown apply to ADF models configured with Option D only.

Available ADF with T-Option Standard Model Configurations

ADF Series AC Sources are available with either single phase output up to 45kVA or with three phase output up to 90kVA. Models listed in the table below are rack mount or bench units. Cabinet systems are pre-wired for both input and output power. For other configurations or power levels and cabinet options, contact factory. All

models shown here require three phase AC input power. The 150/300Vac voltage ranges are still available on T-Option cabinet system. For current ratings for these standard, see standard model table above.

MODEL	Phase Mode ¹	Rated Power ² AC mode	T Voltage Range Vac L-N	Max. AC Current 3 Phase Mode	Max. AC Current 1 Phase Mode	AC Input ³ -2 or -4	Form Factor
1150ADFT	1 Phase	15 kVA	0-400 V	n/a	93.8 Arms	-2 or -4	2x 4U Chassis, Bench or Rackmount
3150ADFT	3 Phase	15 kVA		31.3 Arms	n/a		
1300ADFT	1 Phase	30 kVA		n/a	187.6 Arms	-2 or -4	Fully wired 28U Cabinet power system
3300ADFT	3 Phase	30 kVA		62.5 Arms	n/a		
1450ADFT	1 Phase	45 kVA		n/a	281 Arms		
3450ADFT	3 Phase	45 kVA		93.8 Arms	n/a	-4 Only	Fully wired 36U Cabinet power system
3600ADFT	3 Phase	60 kVA		125.0 Arms	n/a		
Higher	For higher power T Option configurations, contact factory						

Note 1: Single Phase Mode option (M) is available on three phase ADF Models. This option adds single phase output mode.

Note 2: Rated power shown is for Three Phase or Single Phase mode operation. For Split Phase mode, rated power is 2/3.

Note 3: AC input ratings: -2 = 208Vac Nominal, 3ø or -4 = 380~480Vac Nominal, 3ø. See specifications section for AC current requirements.

Technical Specifications

OUTPUT	Specification
Voltage	
Output Mode	AC / Optional DC
1150ADF	Single Phase
3150ADF	Three Phase or Split Phase
Standard Vac Range	0-300 Vac LN / 0-520 Vac LL
Extended Voltage Range ¹ (Option V)	Increases max output voltage to 333Vac LN / 576Vac LL
Vdc Range (Option D)	0 - ± 425 Vdc
Programming Resolution	0.01 V
Accuracy	± 0.25% F.S.
Output Waveform	Sine
DC Offset	< 20 mV
Harmonic Distortion (Vthd) (full, resistive load, up to 300Vrms L-N)	< 400 Hz, < 0.5% 400 to 500 Hz, < 1.0% (Option F: > 500 Hz, < 1.5%)
Output Noise (DC to 300kHz)	< 150 mV RMS
Load Regulation	± 0.02% (CSC Mode)
Line Regulation	< 0.1% for 10% Line Change
Voltage Sense	External Sense, max. voltage drop 5% F.S.
Voltage Slew Rate	AC > 1.0V/us
Output Isolation	550Vac
Frequency	
Standard Range	45.00 – 500.0 Hz
Extended Range (Option F)	15.00 – 1200.0 Hz
Programming Resolution	0.01 Hz
Accuracy	± 0.01%
Current Limit - RMS and Peak Modes	
RMS Range	See model table page 5
Crest Factor	
1150ADF	2.5:1@125A to 6.3:1@50A (312Apk/phase)
3150ADF	2.5:1@41.67A to 6.3:1@16.67A (104Apk/phase)
Programming Resolution	0.01 Arms
Accuracy	± 0.5% F.S.
Current Protection Modes	Constant Current (CC) or Output Trip (CV)
Current Overload Mode	Allows 130% of max. RMS current for up to 2.0 secs before CP is triggered when enabled
Phase Angle (3 Phase ADF Models only)	
Phase Settings	Three Phs Mode: A = 0°, B = 120°, C = 240° Split Phs Mode: A = 0°, B = 180°, C = 0°

Note 1: Supplemental specifications apply for Extended Voltage (Option V).

PROTECTION	Specification
Available Protections	Over Current fold-back or trip
	Prog. Peak Current Limit
	Power fold-back or trip
	App.Power fold-back or trip
	Over Voltage trip
	Over Temperature trip
OVP Programming Range	0 ~ 105% of voltage range
AC Input Voltage	Over and Under Voltage, 15%

MEASUREMENTS	Specification
Voltage (Vrms)	
Range	0 – 350 VLN / 0-600 VLL
Resolution	0.01 V
Accuracy	± 0.25% F.S.
Current (Arms)	
Range	See model table page 7
Resolution	0.01 Arms
Accuracy ¹	± 0.5% F.S.
Current Crest Factor	
Range	1.00 - 5.00
Resolution	0.01
Accuracy ¹	± 2.0% F.S.
Power (W)	
Range	See model table page 7
Resolution	0.01 W
Accuracy ²	± 1.5 % F.S.
Apparent Power (VA)	
Range	See model table page 7
Resolution	0.01 VA
Accuracy ²	± 1.5 % F.S.
Power Factor	
Range ²	0.00 - 1.00
Resolution	0.01
Voltage (Vdc) (Requires Option D)	
Range	0 – 440 Vdc
Resolution	0.01 V
Accuracy	± 0.25% F.S.
Current (Adc) (Requires Option D)	
Range	See model table page 7
Resolution	0.01 Arms
Accuracy ¹	± 0.5% F.S.

Footnotes:

1: For Currents above 2.0 A

2: For Power levels above 100 W

INTERFACES	Description
Remote Control	
USB	Device Type B
RS232	1200 - 921600 baud
LAN	LXI compliant, Ethernet, RJ45, TCP/IP Protocol, Telnet Protocol Command Line
LXI Compliant	 LAN extensions for Instrumentation
GPIO	IEEE488,1, IEEE488.2 (2003 incl., NI HS488) IEC 60488-1, IEC 60488-2 (2004)
	Functions: SH1, AH1, T6, L3, SR1, RL1, DC1, DT1
WiFi	Optional USB WiFi adaptor

SYSTEM FEATURES	Description
DISPLAY	
Type	Full Color, Touch LCD Display
Size	4.3" Diagonal
Resolution	480 x 272 pixels
USB Ports	2 Front Panel, 1 Rear Panel, Type A
SD Card	32 GB max. Capacity
Video Output	Monitor Out, Front Panel

Technical Specifications (continued)

AC INPUT		15 kVA Models ⁵
Mains Voltage Form	4 Wire, L1, L2, L3 and PE	
Frequency	47 - 63 Hz	
-2 AC Input Versions (Available for systems up to 45kVA only)		
Input Voltage Range	208Vac – 240Vac ± 10%	
Nominal Phase Current ¹	54 Arms	
Peak Inrush Current ²	< 1.5 x Irms	
Input Power Factor	> 0.9	
Efficiency	> 85%	
-4 AC Input Versions (Available for all power levels)		
Input Voltage Range	380Vac – 480Vac ± 10%	
Nominal Phase Current ³	30 Arms	
Nominal Phase Current ⁴	24 Arms	
Peak Inrush Current ²	< 1.5 x Irms	
Input Power Factor	> 0.9	
Efficiency	> 85%	

Footnotes:

- 1: Per ADF unit, 3ø, 208V nom. input voltage 3: Per ADF unit, 380V nom. input voltage
 2: Irms = Max. peak inrush current per unit 4: Per ADF unit, 480V nom. input voltage
 5: For parallel systems above 15 kVA, input current is multiplied by the number of units

ANALOG & DIGITAL I/O		Specification
Analog Inputs (4)		Set Voltage phs A, B, C, Freq
Range	0 - 10 Vdc for 0 - F.S.	
Accuracy	± 0.1% F.S.	
Analog Outputs (4)		Meas. phs A, B, C, Power
Range	0 - 10Vdc for 0 - F.S.	
Accuracy	± 0.1% F.S. into > 5 kOhm load	
Digital Inputs (6)		Remote Inhibit, Trigger, Sync
Input Levels	Low < 0.4V, High > 2.0V	
Digital Outputs (6)		Output Relay, /Function Strobe, Phase Sync
Output Levels	Low < 0.4V, High > 4.6V	
Connector Type	DB25, Rear Panel	

DIMENSIONS / WEIGHT	Specification
Dimensions Bench 15kVA Models (4U)	
H x W x D	7.0" x 17.0" x 25.0" 178 x 432 x 635 mm See Note 1 below
Shipping H x W x D	20" x 27" x 38" 508 x 686 x 965 mm
Weight Models up to 15 kVA	
Net	111.2 lbs. / 50.4 kg
Shipping	151 lbs / 68.5 kg

Note 1: Units can be zero-stacked in 19" EIA cabinet when using optional rack-slides. When using L-brackets, allow 1U space between units.

ENVIRONMENTAL	Specification
Cooling	Variable speed fan cooled, front intake with dust filter, rear exhaust
Audible Noise: At 1 meter distance	Standby: 46 dBA Full power: 85 dBA typical
Sleep Modes	Standby, All Power Stages off
Temperature	
Operating	0 to 40 °C / 32 to 104 °F
Storage	-20 to 70 °C / -4 to 158 °F
Humidity	< 80%, non-condensing
Altitude	2000 m / 6500 feet

REGULATORY	Specification
Safety	
Standard	IEC 61010-1:2010 (Edition 3)
EMC	
Emissions Standard	EN 55011:2009+A1:2010
Immunity Standard	EN 61000-4-2, -3, -4, -5, -6, -8, -11
Product Category	EN 61326-1:2013 (Measurement, Laboratory and Control Equipment)
Approvals	CE Mark, NTRL Nemko US/Canada
RoHS (DIRECTIVE 2011/65/EU)	
Product Category	EN50581:2012

Unit Dimensions¹

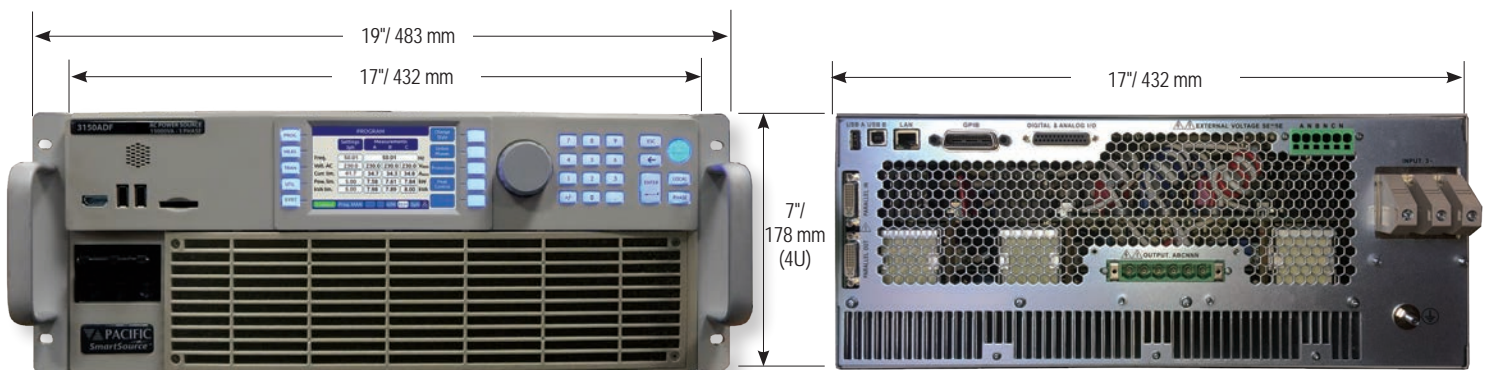

The ADF is designed for bench top or 19" equipment rack operation. Shown with included rack mount handles.

The ADF Rear Panel provides connections for AC Input, AC Output, External Sense, Aux I/O and remote control interfaces.

Note 1: Units can be zero-stacked in 19" EIA cabinet when using optional rack-slides. When using L-brackets, allow 1U space between units.

Ordering Information

Standard Models and Cabinet Systems

Bench Models <input type="checkbox"/> 1150ADF <input type="checkbox"/> 3150ADF	Cabinet Systems¹ <input type="checkbox"/> 1300ADF <input type="checkbox"/> 3600ADF <input type="checkbox"/> 3300ADF <input type="checkbox"/> 3750ADF <input type="checkbox"/> 1450ADF <input type="checkbox"/> 3900ADF <input type="checkbox"/> 3450ADF	Cabinet KIT Systems¹ (x = 2 or 4) <input type="checkbox"/> 1300ADF-xG-KIT <input type="checkbox"/> 3600ADF-4G-KIT <input type="checkbox"/> 3300ADF-xG-KIT <input type="checkbox"/> 3750ADF-4G-KIT <input type="checkbox"/> 1450ADF-xG-KIT <input type="checkbox"/> 3900ADF-4G-KIT <input type="checkbox"/> 3450ADF-xG-KIT	Available Options <input type="checkbox"/> D DC Output Mode <input type="checkbox"/> F Extended Frequency Range <input type="checkbox"/> M Single Phase Mode on 3xxxADF <input type="checkbox"/> O Output control switch <input type="checkbox"/> T Output Transformer 400V Range <input type="checkbox"/> V Extended Voltage Range
Auxiliary Models (No controller) <input type="checkbox"/> 1150ADF-2NC / 1150ADF-4NC <input type="checkbox"/> 3150ADF-2NC / 3150ADF-4NC	Input Voltage (V_{IN}) <input type="checkbox"/> -2 208V - 240Vac, 3Ø ± 10%, 47-63Hz <input type="checkbox"/> -4 380V - 480Vac, 3Ø ± 10%, 47-63Hz		Export Version <input type="checkbox"/> E Append "E" postfix or none

Note 1: Cabinet systems consist of one master unit and one or more auxiliary units integrated into a 19 inch EIA instrument grade cabinet. Includes input and output wiring to rear mounted compression terminal blocks. Other cabinet options available. Customers that require the use of their own cabinets can order system packages without cabinet (-KIT). Contact factory for ordering information.

Order Example

3150ADF-4G
 Bench Model, 15 kVA, 3-Phase, AC Power Source with USB, RS232, LAN, GPIB & AUX I/O, 380~480Vac 3 Phase AC Input Voltage

Typical Delivery Items

- AC Power Source
- English Manuals in PDF Format
- Rack Mount Handles
- Certificate of Compliance

Available Accessories

- Paralleling Cable, 1 Ft. (Included with Aux models). P/N 778036
- Rack slides. P/N 703251

ADF Model Number Encoder:

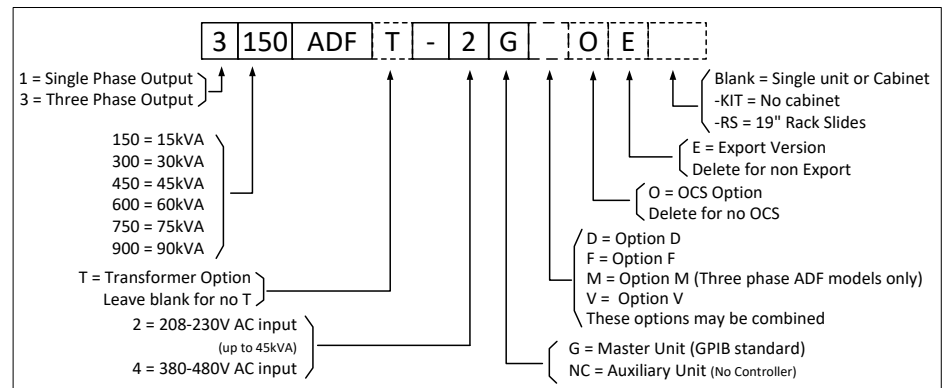

Service and Support

Pacific Power Source's customer support is second to none. Our Customer Support Program provides the training, repair, calibration, and technical support services that our customers value. In addition to receiving the right test equipment, our customers can also count on excellent support before, during and after the sale. With company owned support and service centers around the world, support is never far away. Complete calibration and repair services are offered at our US, European and Chinese manufacturing facilities (see contact info below). Calibrations are to original factory specifications and are traceable to NIST (National Institute of Standards and Technology).

NORTH AMERICA

Pacific Power Source, Inc.
 Irvine, USA
 Phone: +1(949) 251-1800
 Fax: +1 (949) 756-0756
 Email: info@pacificpower.com
 Web: www.pacificpower.com

EUROPE

Pacific Power Source Europe GmbH.
 Kappelrodeck, Germany
 Phone: +49 7842 99722-20
 Fax: +49 7842 99722-29
 Email: info@pacificpower.eu
 Web: www.pacificpower.eu

CHINA

PPST Shanghai Co. Ltd.
 Shanghai, China
 Phone: +86-21-6763-9223
 Fax: +86-21-5763-8240
 Email: info@ppst.com.cn
 Web: www.ppst.com.cn

Proudly Represented by:



2802 Kelvin Avenue, Suite 100
 Irvine, CA 92614 -5897 USA
 Phone: +1 949.251.1800
 Fax: +1 949.756.0756
 Toll Free: 800.854.2433
 E-mail: sales@pacificpower.com
 Web: www.pacificpower.com